



ULTRA SM 2.0

Touch Screen,
PLC Control



Easy to change
and set blades

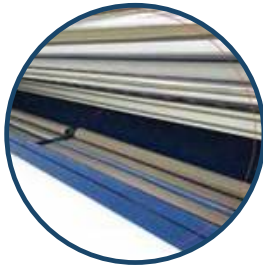

Automatic
Rewinding and
Extraction

The **ULTRA SM 2.0 Multi-Blade Cutting Machine** is a cutting-edge solution for manufacturing sheer elegance or zebra shades in high volumes. This state-of-the-art machine is equipped with four cutting heads to simultaneously cut multiple shades at once, ensuring large quantities of fabric can be cut with precision and speed. Using this tool helps to minimize waste and maximize production efficiency.



CUTTING WIDTH:
3M (9' 10")



OPTIONAL UPGRADES:
Additional Cutting Unit
Additional Stainless Steel Tube
MES Data Transportation
Additional Conveyor



TECHNICAL SPECS:

Wattage: 300 Watts
Air Requirements: 6 kg/cm2
Voltage: 110V or 220V, Single Phase

Features

- ✓ Longitude (Y axis) and Latitude (X axis) cutting is performed simultaneously by Knife Blade
- ✓ Cut Multiple Shades at Once
- ✓ Four Separate Cutting Heads on Unit
- ✓ Automatic Length Configuration Feature for Various Band Sizes
- ✓ Adjustable Alignment Feature for Various Band Sizes
- ✓ Automatic Fabric Roll Pulling and Tension Control
- ✓ Manufacturing Execution System (MES) Data Transportation Feature Available

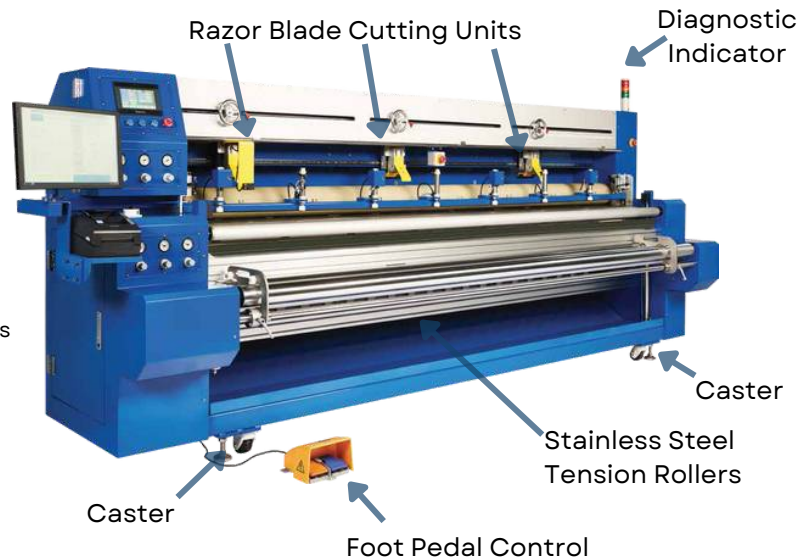

ULTRA SM 2.0

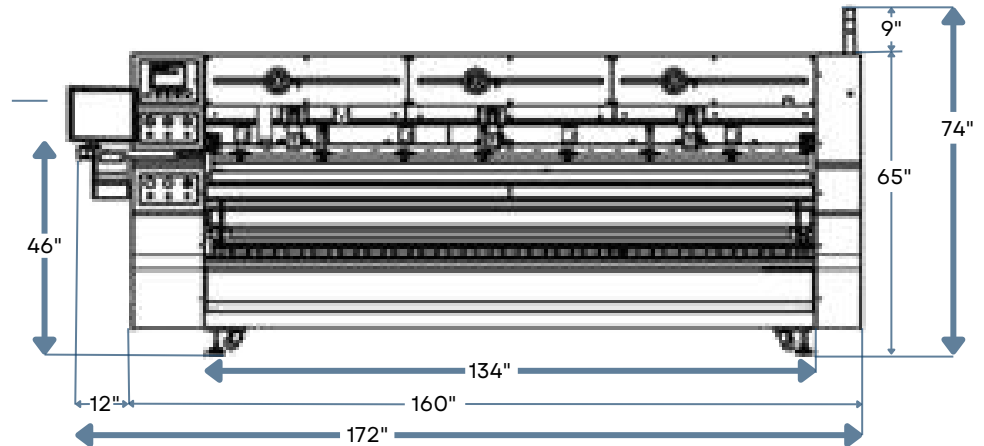
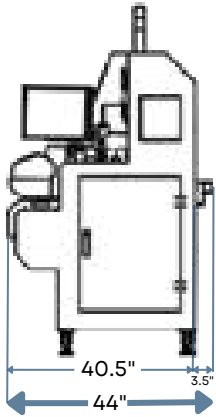

Dimensions

Approximate dimensions included for reference, final measurements may vary. Ultratab equipment is made-to-order, please consult your Senbesta Sales Rep. for more details.



SHIPPING

FOB Glendora, CA: 10-12 week lead-time on average. Equipment will be shipped from Senbesta's Glendora, CA warehouse.



INSTALLATION & TRAINING

2 days of set-up and initial operator training are included. Training will be performed by a Senbesta technician onsite at the customer's facility. All travel expenses will be covered by the customer for the technician from California.



MANUFACTURER WARRANTY

Within the first 12 months you receive the machine, we will repair/replace any manufacturing defect without charge for parts or labor.